

# **Metro** **SMARTvent™**

***Ventilation done right!***

Metro's dedication to world-class design has resulted in an industry first: a fully integrated ventilator panel called SMARTvents.

Metro SMARTvents are available for all Metro panel profiles. They are formed from Shake, Shingle, Tile or the newest Roman Tile panels incorporating baffled attic ventilation and are made from the same long-life steel and stone-coating as Metro panels.

SMARTvents create a single, functional unit that integrates perfectly with the surrounding roof panels, eliminating labor-intensive flashing details.

To reap the benefits of reduced labor and a clean smart looking roof, use Metro SMARTvents along with the Metro roof system.



*Smart Roofs for Smart People™*



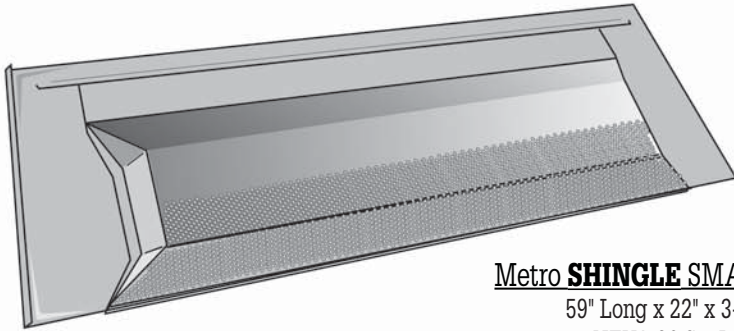

**Metro SHINGLE SMARTvent**  
59" Long x 22" x 3-1/2" High  
NFVA 90 Sq. In. Approx.

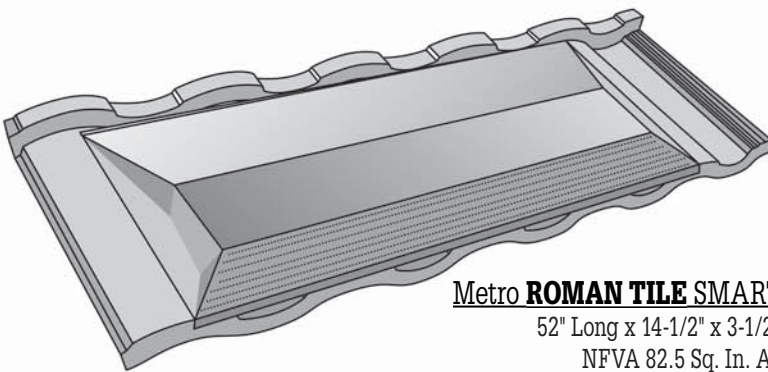

**Metro ROMAN TILE SMARTvent**  
52" Long x 14-1/2" x 3-1/2" High  
NFVA 82.5 Sq. In. Approx.

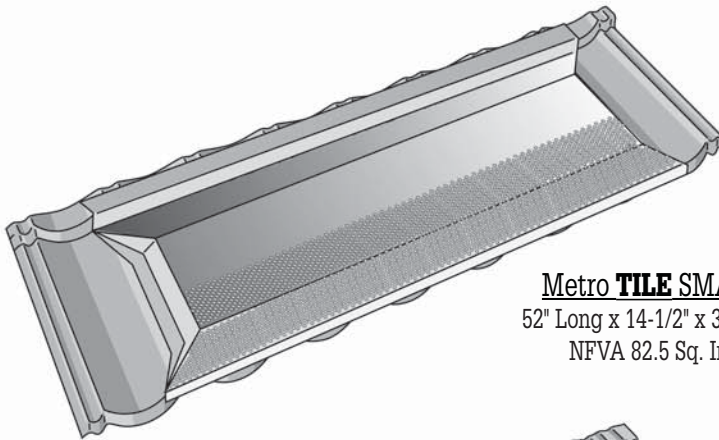

**Metro TILE SMARTvent**  
52" Long x 14-1/2" x 3-1/2" High  
NFVA 82.5 Sq. In. Approx.

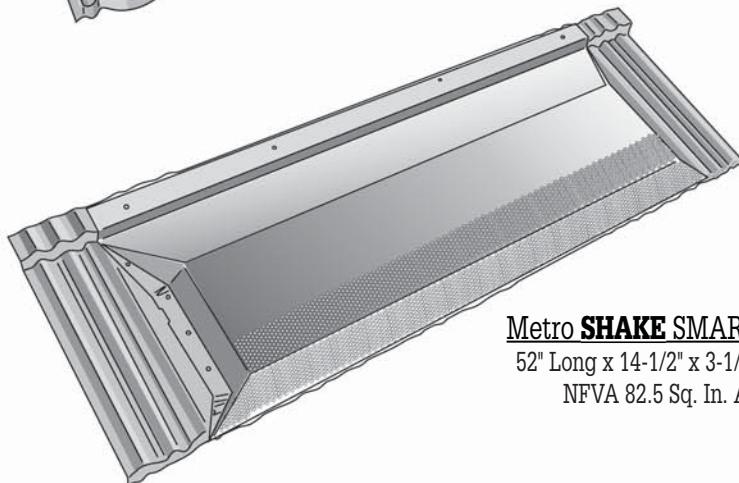

**Metro SHAKE SMARTvent**  
52" Long x 14-1/2" x 3-1/2" High  
NFVA 82.5 Sq. In. Approx.

All Metro roofs carry a 50-year limited warranty, covering 120-mph winds, class-4 Hail Impact, and Class-A fire resistance. Year after year, Metro's long-life 25-year limited appearance warranty protects your investment, making Metro the smartest roof you can buy.

During the roof selection process additional consideration should be given to the ventilation characteristics of a building. A properly ventilated building breathes sufficiently to prevent the build-up of excess heat and moisture in an attic. Code requires the net free vent area (NFVA) to be not less than 1 to 150 of the area of the space ventilated. Proper ventilation includes sharing the open vented space between the eaves and ridgelines of a building. Metro SMARTvents are an efficient and unobtrusive way of increasing a building's ventilation.

The finished Metro SMARTvent is stone-coated in the same quality finish as every Metro roof panel and lays neatly into the roof just like a single panel without the need for time consuming flashing. The final result is clean, quick installation that meets all of the new code requirements for roof venting.

For more information on Metro Roof Products and its expanding line of innovative accessories, ask your local roofing contractor or distributor for a FREE estimate.



*Smart Roofs for Smart People™*

3093 Industry Street  
Oceanside CA 92054  
**Tel: (866) 638-7648**  
Fax: (760) 435-1162  
[www.metroroofs.com](http://www.metroroofs.com)

**Metro Roman Tile - PATENT**  
Design Patent No. 29/221691, 21 January 2005

™Zincalume® is a registered trademark of BIEC International, Inc.  
©2006 Metro Roof Products 051006-25M