

110 MPH

EXPOSURE: 'C'

HEIGHT: 30 ft (Mean)

WIND RESISTANCE ASSEMBLY

Speed: 110 MPH.
Building Height: 30-FT.
Exposure: 'C'

FIELD (1)
-21.6 PSF

EDGE (2)
-40.8 PSF

CORNER (3)
-62.4 PSF

Metro Roof Products
3093 'A' Industry Street
Oceanside CA 92054
PH 760-435-9842
www.smartroofs.com

Panels on 1X4 BATTENS

DESIGN CRITERIA:

The design criteria for uplift resistance pressures for a mean roof height as noted, is developed using ASCE 7.05. Minimum Design Wind Uplift Pressures in PSF for FIELD (P(1), EDGE (P(2), and CORNER (P(3) for Exposure 'C' Buildings with a Mean Roof Height as specified.

ROOF WIND ZONE: (1) 'FIELD' Uplift Req., = -21.6 PSF (UL TGIK R19204 Uplift Resistance -#10,-115.00 PSF)

DECKING	Min., 15/32" in. thick, Grade B-C APA rated Plywood or equal. Each course must have continual support across roof at the back-lip of each panel.
BATTENS	1X4" in. panel battens laid perpendicular to rafters and spaced at 14-1/2" in O/C up the rafter and attached with two (2) 16-d nails (.131" dia X 3-1/4") @ 24" inches O/C at each rafter & 1X4 intersection.
* PANELS	Panels fastened through the front nose downturn with Six (6) Ring Shank nails per panel. Nails are min- .113" Dia X 2" Ring Shank nails.

ROOF WIND ZONE: (2) 'EDGE' Uplift Req., = -40.8 PSF (UL TGIK R19204 Uplift Resistance -#10,-115.00 PSF)

DECKING	(See ZONE (1) above)
BATTENS	(See ZONE (1) above)
* PANELS	(See ZONE (1) above)

ROOF WIND ZONE: (3) 'CORNER' Uplift Req., = -62.4 PSF (UL TGIK R19204 Uplift Resistance -#6,-170.00 PSF)

DECKING	(See ZONE (1) above)
BATTENS	1X4" in. panel battens laid perpendicular to rafters and spaced at 14-1/2" in O/C up the rafter and attached with four (4) 16-d nails (.131" dia X 3-1/4") @ 24" inches O/C at each rafter & 1X4 intersection.
* PANELS	Panels attached through the front downturn with Eight (8) #8 X 1-1/2"-inch long screws per panel.

1X4 PANEL BATTEN FASTENING 2 Nails for Zone 1 & 2

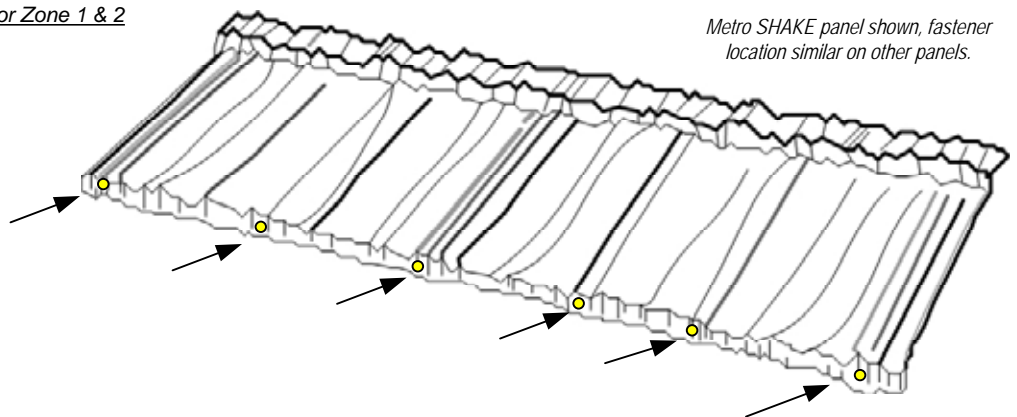
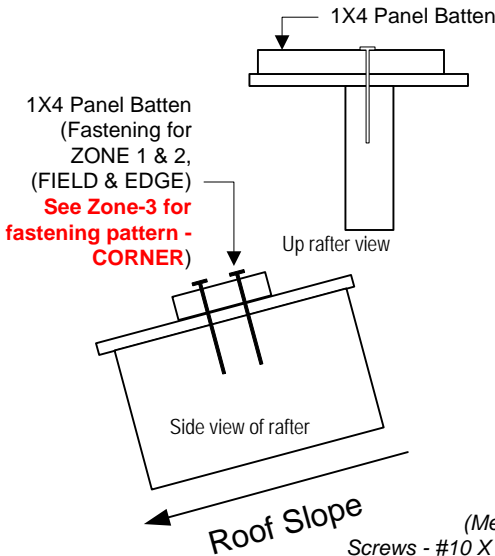

Drawings show fastening pattern for ZONES 1, & 2 – FIELD & EDGE
See Zone-3 for fastening pattern - CORNER.

(Metro provided fasteners may be used as follows for panel fastening:
Screws - #10 X 2-inch long Hex Head Nails - .131" Dia X 2 inch long Ring Shank)

Roofs have designated ROOF WIND ZONES identified as FIELD (P(1), EDGE (P(2), or CORNER (P(3). ASCE 7.05 Uses 3-Sec gust calculation formulas.