

**100 MPH****EXPOSURE: 'C'****HEIGHT: 30 ft (Mean)****WIND RESISTANCE ASSEMBLY**

**Speed: 100 MPH.**  
**Building Height: 30-FT.**  
**Exposure: 'C'**

**FIELD (1)**  
**-17.9 PSF**

**EDGE (2)**  
**-33.8 PSF**

**CORNER (3)**  
**-51.7 PSF**

Metro Roof Products  
 3093 'A' Industry Street  
 Oceanside CA 92054  
 PH 760-435-9842  
 www.smartroofs.com

**Panels on 1X4 BATTENS**

**DESIGN CRITERIA:**

The design criteria for uplift resistance pressures for a mean roof height as noted, is developed using ASCE 7.05. Minimum Design Wind Uplift Pressures in PSF for FIELD (P(1), EDGE (P(2), and CORNER (P(3) for Exposure 'C' Buildings with a Mean Roof Height as specified.

**ROOF WIND ZONE: (1) 'FIELD' Uplift Req., = -17.9 PSF** (UL TGIK R19204 Uplift Resistance -#10,-115.00 PSF)

DECKING	Min., 15/32" in. thick, Grade B-C APA rated Plywood or equal. Each course must have continual support across roof at the back-lip of each panel.
BATTENS	1X4" in. panel battens laid perpendicular to rafters and spaced at 14-1/2" in O/C up the rafter and attached with two (2) 16-d nails (.131" dia X 3-1/4") @ 24" inches O/C at each rafter & 1X4 intersection.
* PANELS	Panels attached through the front downturn with Six (6) Ring Shank nails per panel. Nails are min- .113" Dia X 2" Ring Shank nails.

**ROOF WIND ZONE: (2) 'EDGE' Uplift Req., = -33.8 PSF** (UL TGIK R19204 Uplift Resistance -#10,-115.00 PSF)

DECKING	(See ZONE (1) above)
BATTENS	(See ZONE (1) above)
* PANELS	(See ZONE (1) above)

**ROOF WIND ZONE: (3) 'CORNER' Uplift Req., = -51.7 PSF** (UL TGIK R19204 Uplift Resistance -#10,-115.00 PSF)

DECKING	(See ZONE (1) above)
BATTENS	(See ZONE (1) above)
* PANELS	(See ZONE (1) above)

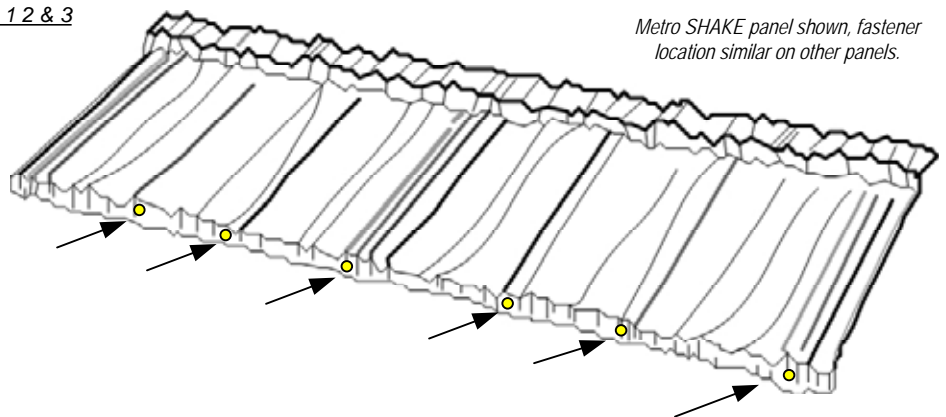
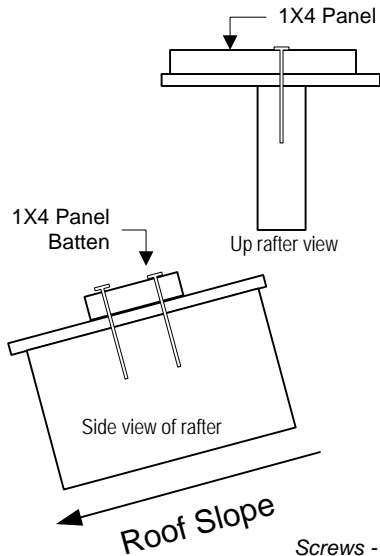
**1X4 PANEL BATTEN FASTENING 2 Nails for Zone 1 2 & 3**

Arrows indicate nose fastener locations for FIELD-1, EDGE-2 & CORNER-3.

(Metro provided fasteners may be used as follows for panel fastening:  
 Screws - #10 X 2-inch long Hex Head      Nails - .131" Dia X 2 inch long Ring Shank)

Roofs have designated ROOF WIND ZONES identified as FIELD (P(1), EDGE (P(2), or CORNER (P(3). ASCE 7.05 Uses 3-Sec gust calculation formulas.